

GRAPHIC INFORMATION

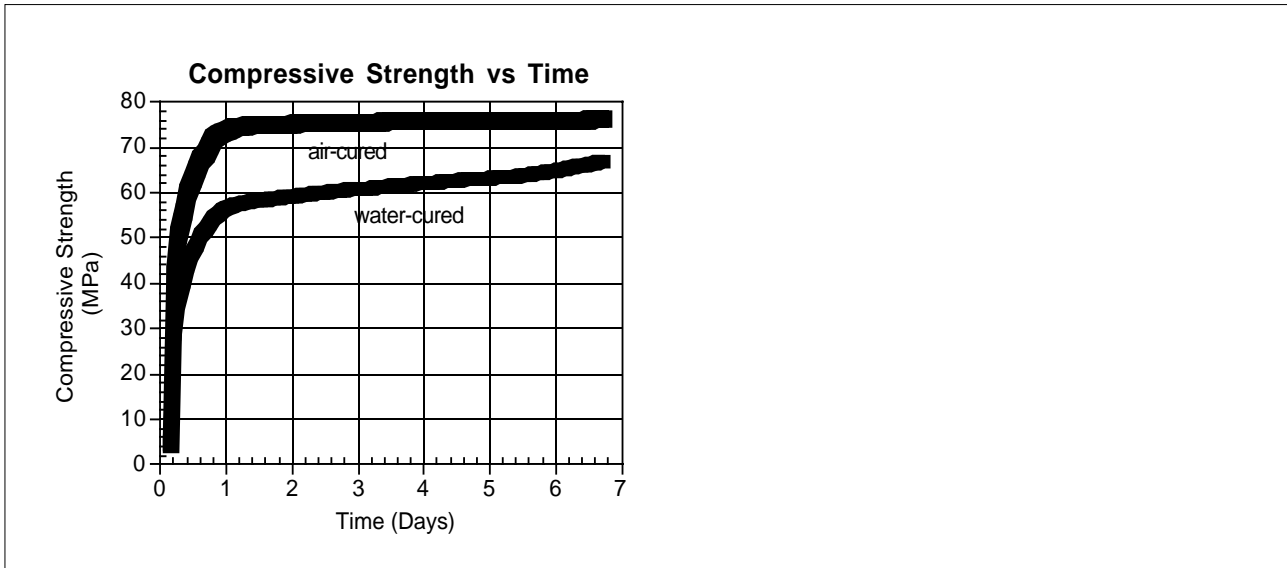

PACKAGING

ALPHATEC 141 is packed in a unit yielding 11 liters. The components are pre-measured, and should normally be mixed as a unit.

- Base: 1 x 2.5 kg in 18 liter pail
- Hardener: 1 x 1.4 kg in 2 liter plastic bottle
- Aggregate: 1 x 20.0 kg in waterproof paper bag

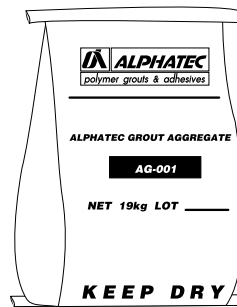
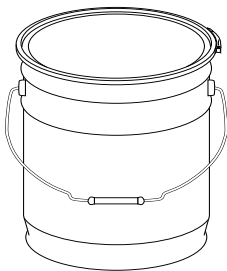

MIXING & HANDLING

Pour full amount of hardener into Liquid pail and mix for at least 2 minutes with an air or electric-powered pail mixer. Add aggregate slowly, and mix until all aggregate particles are coated with resin. See "General Instructions for the Use & Handling of Polymer Grouts" for further details.

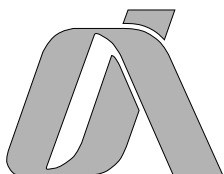
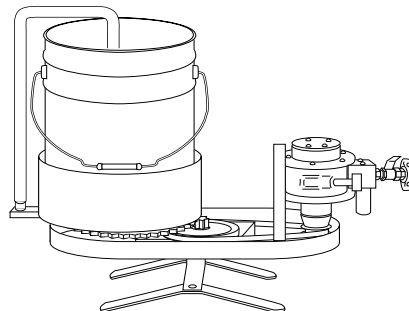

Alphatec Holdings Pte Ltd 3 Shenton Way, Singapore.

Alphatec Holdings licenses various Alphatec Engineering group companies to manufacture these products in specific markets. Consult your local supplier for more information.